



**ARJES**

Recycling Innovation







***TITAN***  
***THE HEAVY-DUTY CLASS***

# OUR SHREDDERS OF THE ARJES HEAVY-DUTY CLASS



When choosing the right machine, our customers are usually faced with the question of which shredder is right for their specific requirements. Therefore, we have divided our unique double-shaft shredders into three product lines to help you make the right decision.

## Fields of application TITAN class

-  Waste Wood & Biomass
-  Household & Commercial Waste
-  Construction & Demolition Waste
-  Scrap Metal & Car Bodies

Find out more about our applications and tool shafts in the brochure  
**RECYCLING IS OUR GLOBAL SOLUTION**



## PRODUCT LINE **TITAN**

The TITAN class is all about the heaviest chunks and the most demanding applications. Where many throw in the towel, we take on the challenge and seek to satisfy with a competitively superior range of applications. Especially companies that have to process a huge amount of waste products on a daily basis find themselves at home within this price range. Our mobile shredders are available in two versions and include, as standard series, a track system. The TITAN shredders are equipped with a revolutionary quick change shaft system, an innovative SCU control as well as specifically designed shafts that meet the most challenging requirements.

Alternatively, the ARJES heavy-duty class also offers the possibility of using a stationary electric or diesel version, in which the twin-shaft shredders convinces with maximum efficiency. The system is divided into a drive and control unit and can be integrated into existing recycling plants or used as a stand-alone machine.

Numerous applications for our machines can be found in the construction and demolition industry, in the shredding of mixed scrap, car bodies, car, truck, AG & EM tyres, in the processing of domestic and commercial waste, as well as, in composting and wood processing plants.

### THROUGHPUT RATES\*

Construction waste	Ø 180 – 200 t/h
Concrete / Asphalt	Ø 140 – 160 t/h
Waste wood	Ø 100 – 150 t/h
Biomass	Ø 150 – 200 t/h
Waste & Plastics	Ø 40 – 50 t/h
Car bodies	Ø 25 – 30 t/h
Scrap Metal	Ø 25 – 30 t/h

\*Depends on the equipment of the shredder, the shaft configuration and the optimum material feed. The performance data given are average values without guarantee!

# TITAN 900 *The highlights of the mobile heavy-duty class in detail*



## REVERSING FAN

**Included!** Self cleaning CLEANFIX fan for ideal air circulation and dirt reduction in the engine compartment



## SHREDDING UNIT

Large-volume hopper and double shaft system with quick-change cassette



## SCU-CONTROL SYSTEM

Including **remote control** and predefined shredding programs that adjust rotation and speed of shafts



## TRACK SYSTEM

**Included!** Guaranteed high mobility on uneven surfaces

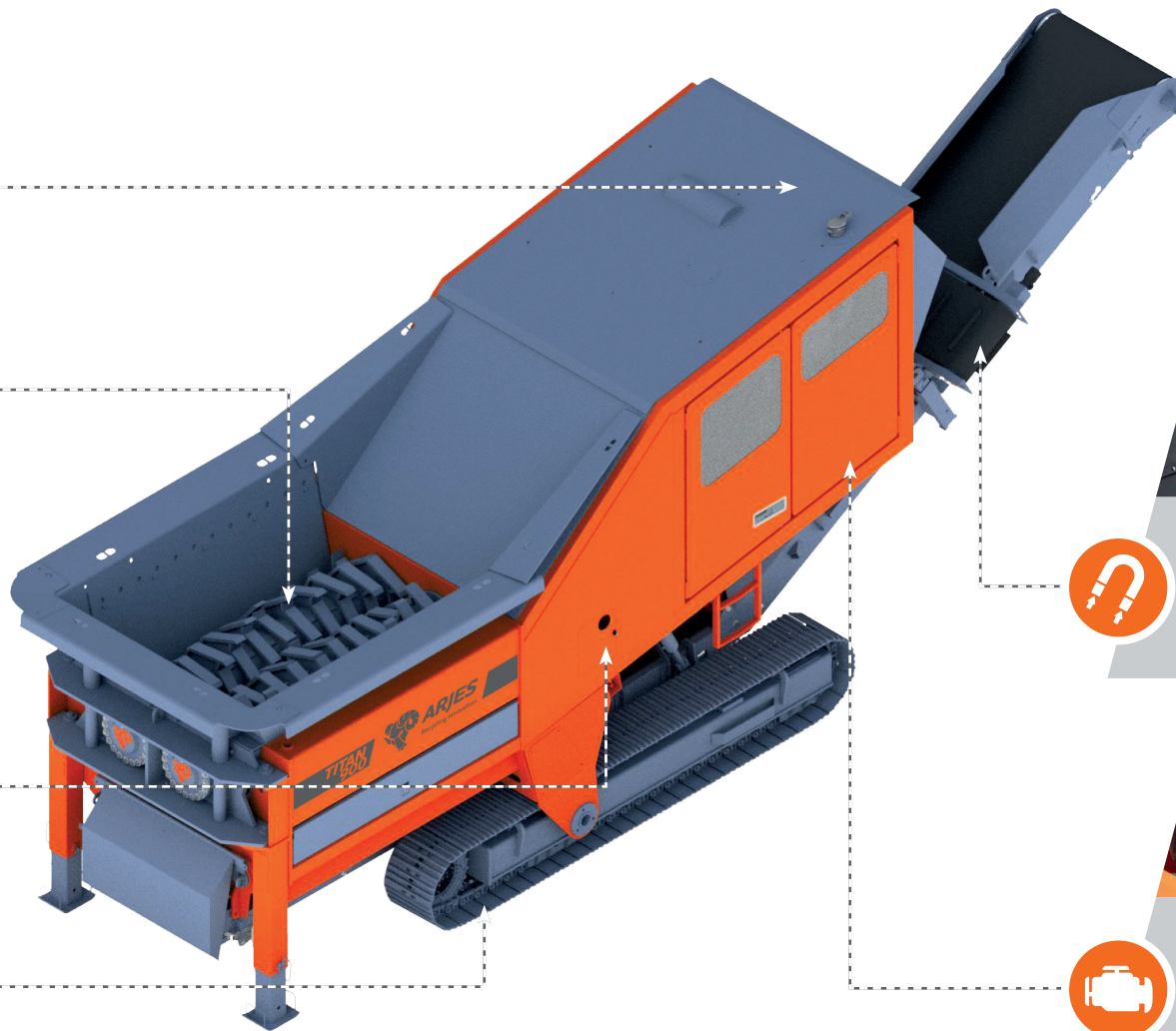

## MAGNET

**Included!** Height-adjustable permanent magnet for effective Fe-separation



POWERED BY  
**VOLVO PENTA**

## DRIVE

Powerful **VOLVO PENTA** diesel engine for the maximum efficiency during the shredding process



## TECHNICAL DATA

### DIMENSIONS

Version	Track system
Length (mm)	11.000 / 11.000 (Transport)
Width (mm)	3.000 / 3.000 (Transport)
Height (mm)	4.200 / 3.700 (Transport)
Total weight (kg)	35.000

### DRIVE

	EU / US	ROW*
Engine (Volvo Penta)	TAD 1385 VE	TAD 1650VE-B
Emission standard	Stage V / EPA Tier IV	Stage III A
Power (kW / HP)	405 / 550	
Fuel capacity (l)	800	
Gearbox	Bonfiglioli	

### DISCHARGE BELT

Discharge height (mm)	max. 4.000
Width (mm)	1.200
Included	Height adjustable over-belt magnet

### SHREDDING UNIT

Hopper volume (m <sup>3</sup> )	5
Shaft length (mm)	2.500
Shaft diameter (mm)	860
Weight (kg / cassette)	6.700
Rotation speed (rpm)	15 – 45



### Easy maneuvering and transportability

The standardised track system provides optimal mobility at the operational site and makes transportation on a low-bed truck even more affordable and efficient.

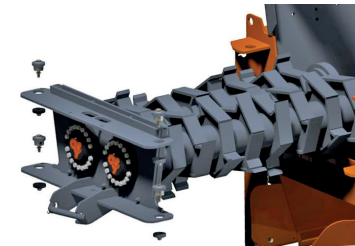

### Quick change system for shafts

Easy installation and quick removal of shafts, for easier maintenance, refurbishment and changing of shaft type, which increases productivity.

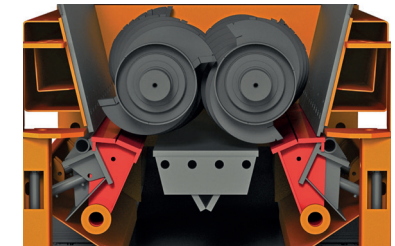

### Hydraulic adjustable side combs

The side combs can be opened or closed to regulate the final grain size. This allows the throughput to be defined depending on the material and the customer's requirements.

\*Rest of the world (country-specific requirements)

# TITAN 900 e-pu/d-pu *The highlights of the stationary heavy-duty class in detail*

## SHREDDING UNIT

Large-volume hopper and double shaft system with **quick-change cassette**

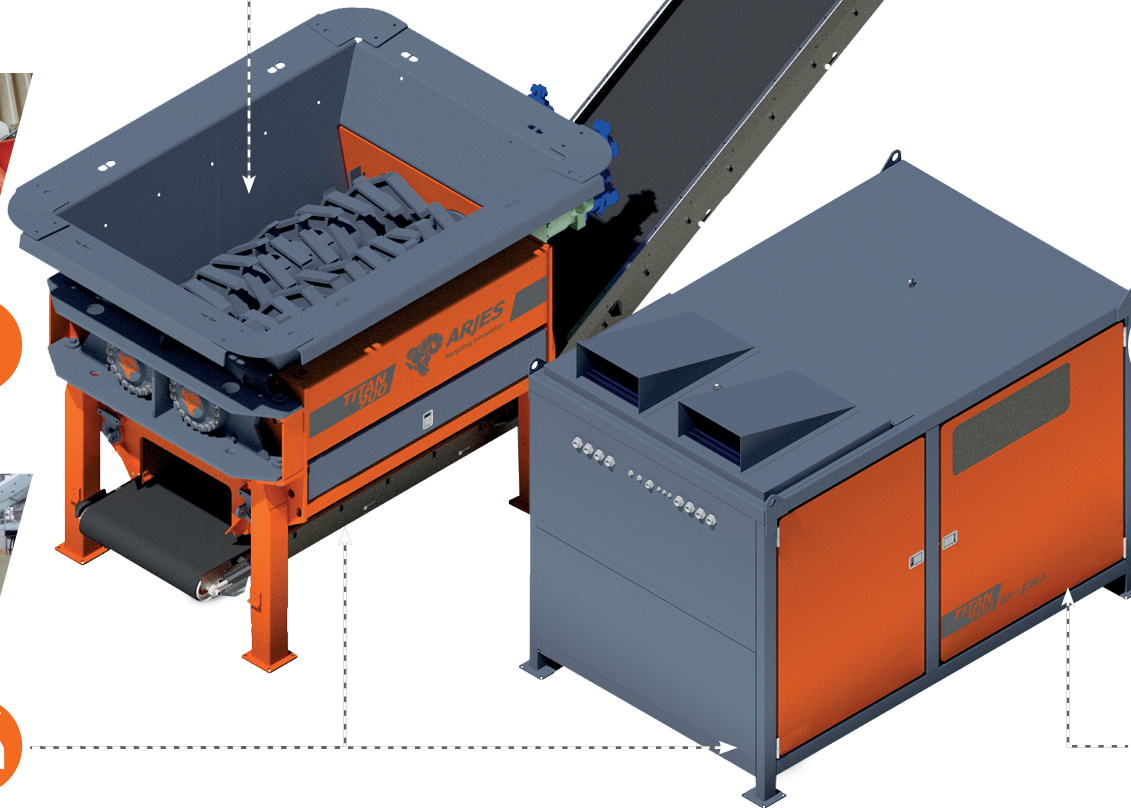

## DISCHARGE BELT

**Optional!** Conveyor belt for efficient material discharge according to customer requirements



## MAGNET

**Optional!** Height-adjustable permanent magnet for effective Fe-separation

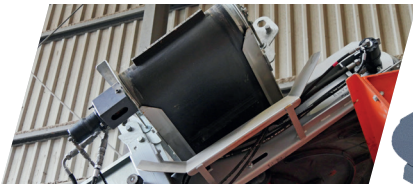

## CONTROL SYSTEM

Operation via **remote control** and optional integration into complete systems possible according to customer requirements



## STATIONARY

Use as stand-alone machine or optional integration into recycling plants according to customer requirements



## DRIVE (e-pu / d-pu)

Two powerful **electric engines** or one **diesel engine** for off-grid operations

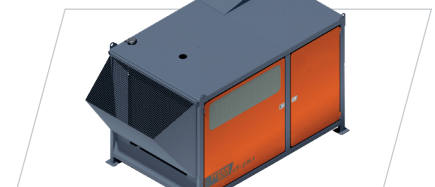

## TECHNICAL DATA

### DIMENSIONS

Version	Stationary
Shredding Unit	
Length (mm)	4.700
Width (mm)	3.000
Height (mm)	3.100
Control Unit	
Length (mm)	3.500
Width (mm)	2.300
Height (mm)	2.300
Total weight (kg)	approx. 22.000

### DRIVE

Engine	Electric	Diesel (13 l Stage V)
Power (kW)	2 x 160	405
Gearbox	Bonfiglioli	

### SHREDDING UNIT

Hopper volume (m <sup>3</sup> )	5
Shaft length (mm)	2.500
Shaft diameter (mm)	860
Weight (kg / cassette)	6.700
Rotation speed (rpm)	15 – 45



### Separate drive and control unit

Due to separate placement of the shredding and control unit (max 8 meters in between) there is significant less vibration to the control system. Additionally, dust and dirt are reduced

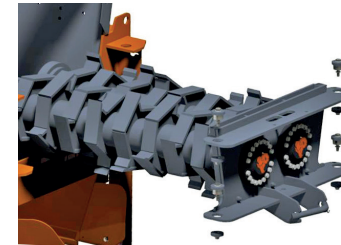

### Quick change system for shafts

Easy installation and quick removal of shafts, for easier maintenance, refurbishment and changing of shaft type, which increases more productivity.

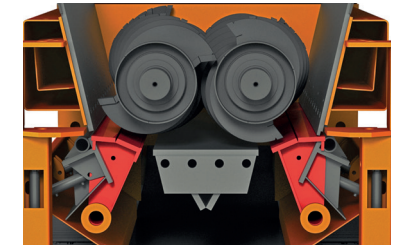

### Hydraulic adjustable side combs

The side combs can be opened or closed to regulate the final grain size. This allows the throughput to be defined depending on the material and the customer's requirements.

# TITAN 950 *The highlights of the mobile heavy-duty class in detail*

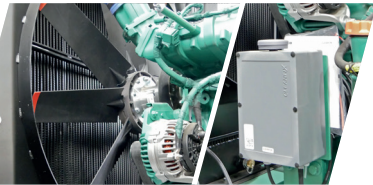

## REVERSING FAN

**Included!** Self cleaning CLEANFIX fan for ideal air circulation and dirt reduction in the engine compartment



## SHREDDING UNIT

Large-volume hopper and double shaft system with quick-change cassette



## SCU-CONTROL SYSTEM

Including remote control and predefined shredding programs that adjust rotation and speed of shafts



## TRACK SYSTEM

**Included!** Guaranteed high mobility on uneven surfaces



## MAGNET

**Included!** Lengthwise, built-in rigid permanent magnet for effective Fe separation



## CROSS BELT

**Included!** For lateral discharge of the separated non-ferrous fraction



## DRIVE

Powerful **VOLVO PENTA** diesel engine for the maximum efficiency during the shredding process.





## TECHNICAL DATA

### DIMENSIONS

Version	Track system
Length (mm)	13.000 / 13.000 (Transport)
Width (mm)	5.700 / 3.000 (Transport)
Height (mm)	4.500 / 3.700 (Transport)
Total weight (kg)	37.000

### DRIVE

	EU / US	ROW*
Engine (Volvo Penta)	TAD 1385 VE	TAD 1650VE-B
Emission standard	Stage V / EPA Tier IV	Stage III A
Power (kW / HP)	405 / 550	
Fuel capacity (l)	800	
Gearbox	Bonfiglioli	

### DISCHARGE BELT

Discharge height (mm)	max. 3.600
Width (mm)	1.000 (Ne-Fraction) 1.400 (Fe-Fraction)
Included	Cross belt and lengthwise magnet

### SHREDDING UNIT

Hopper volume (m <sup>3</sup> )	5
Shaft length (mm)	2.500
Shaft diameter (mm)	860
Weight (kg / cassette)	6.700
Rotation speed (rpm)	15 – 45



Scan QR-Code and watch the TITAN 950 in action!



### Easy maneuvering and transportability

The standardised track system provides optimal mobility at the operational site and makes transportation on a low-bed truck even more affordable and efficient.



### Quick change system for shafts

Easy installation and quick removal of shafts, for easier maintenance, refurbishment and changing of shaft type, which increases more productivity.



### Automatic pressure controlled damping system

If the resistance is too high, the side combs retract inwards and outwards hydrologically. This prevents damage to the shredding unit and regulates the size of the shredded material.

\*Rest of the world (country-specific requirements)

# TITAN 950 e-pu/d-pu *The highlights of the stationary heavy-duty class in detail*

## SHREDDING UNIT

**Specially reinforced** volume hopper and double shaft system with quick-change cassette (optional hopper elevation)

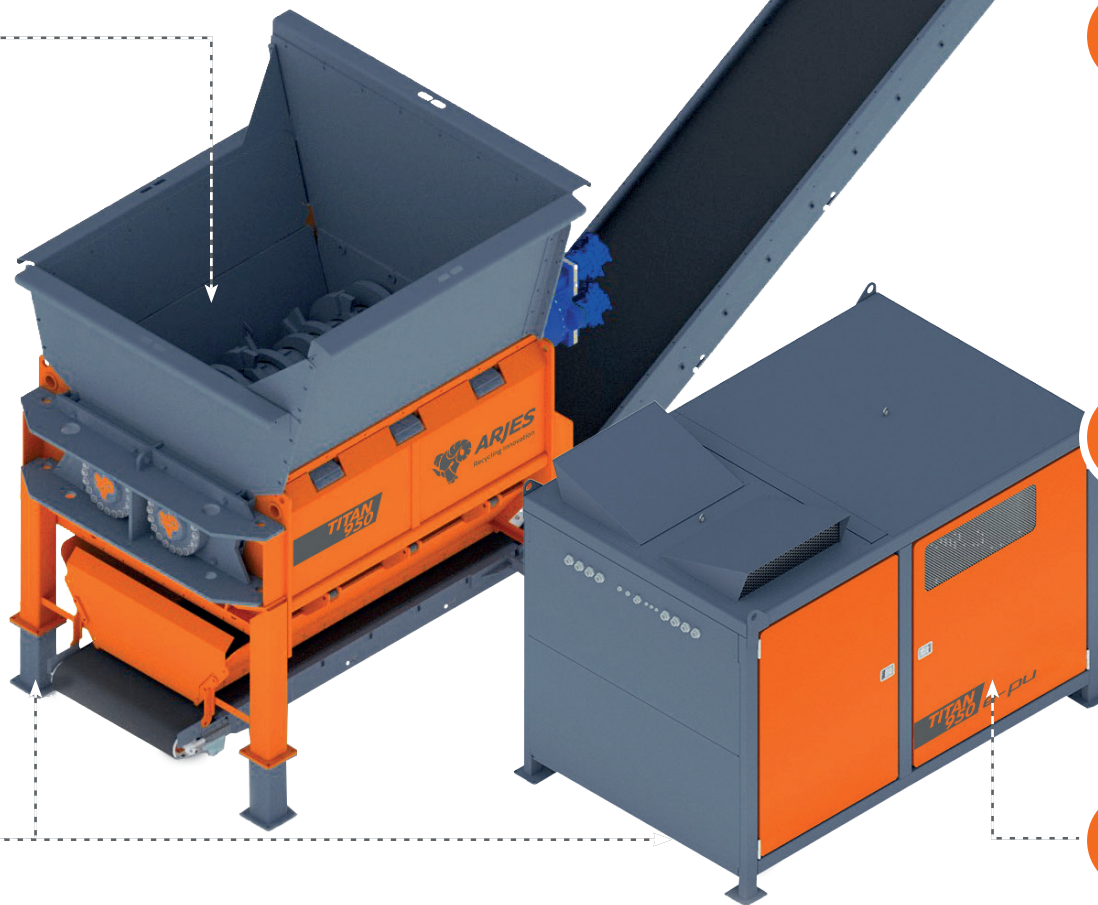

## DISCHARGE BELT

**Optional!** Conveyor belt for efficient material discharge according to customer requirements



## MAGNET

**Optional!** Height-adjustable permanent magnet for effective Fe-separation

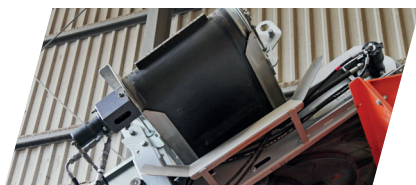

## STATIONARY

Used as an individual machine or optional integration in recycling plants according to customer requirements



## CONTROL SYSTEM

Operation via **remote control** and optional integration into complete systems possible according to customer requirements



## DRIVE (e-pu / d-pu)

Two powerful **electric engines** or one **diesel engine** for off-grid operations

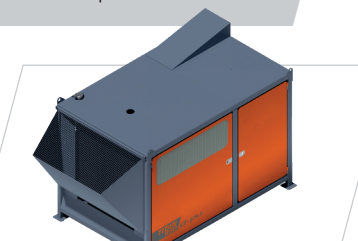

## TECHNICAL DATA

### DIMENSIONS

Version	Stationary
Shredding Unit	
Length (mm)	4.500
Width (mm)	3.200
Height (mm)	3.500*
Control Unit	
Length (mm)	3.500
Width (mm)	2.300
Height (mm)	2.700
Total weight (kg)	approx. 32.000

### DRIVE

Engine	Electric	Diesel (13 l Stage V)
Power (kW)	2 x 250	405
Gearbox	Bonfiglioli	

### SHREDDING UNIT

Hopper volume (m³)	5
Shaft length (mm)	2.500
Shaft diameter (mm)	860
Weight (kg / cassette)	6.700
Rotation speed (rpm)	15 – 45

\*standard configuration; optional hopper increase to 4,200 mm possible



### Separate drive and control unit

Due to separate placement of the shredding and control unit (max 8 meters in between) there is significant less vibration to the control system. Additionally, dust and dirt are reduced

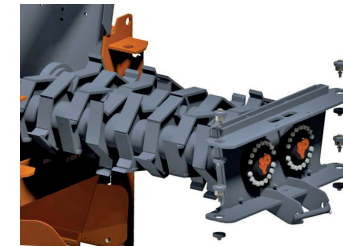

### Quick change system for shafts

Easy installation and quick removal of shafts, for easier maintenance, refurbishment and changing of shaft type, which increases more productivity.

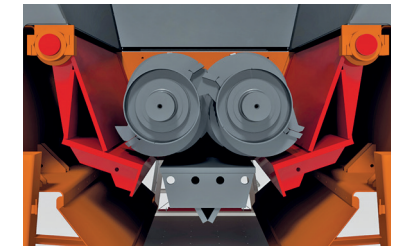

### Hydraulically damped side combs

For particularly large and heavy metal parts, the suspension of the hydraulically side combs is located above the shafts, these are automatically folded out in the event of excessive resistance.



**ARJES GmbH**  
Borntalstraße 9  
D-36460 Krayenberggemeinde  
✉ info@arjes.de  
🌐 [www.arjes.de](http://www.arjes.de)

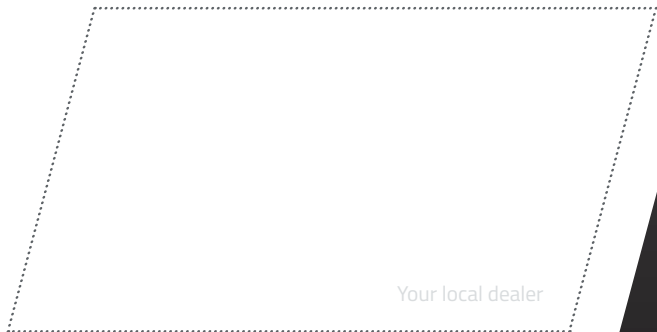

Disclaimer: We reserve the right to make technical changes, misprints and errors. All specifications refer to the standard version without optional features. Status: July 2023



## 5 CONVINCING ARGUMENTS FOR OUR HEAVY-DUTY CLASS

- 1 Best price-performance ratio in its class**  
Including standard attachments\* (e.g. overbelt magnet)
- 2 Largest range of applications**  
Processing of many types of material with the toughest requirements (such as cars, household and industrial waste, AG/EM-tyres, railway sleepers etc.)
- 3 Revolutionary shaft quick-change system**  
Shortens maintenance times, refurbishment and changing of the different shaft types for uninterrupted operation
- 4 Maximum mobility in every situation**  
Standardized track system\* and cost-effective transportation
- 5 Innovative SCU plug-and-play control**  
Predefined shredding programs that control rotation and speed of shafts for user-friendly operability

\*only available for mobile machines